

KOMPAKTOR[®] for High Pressure Roller Grinding

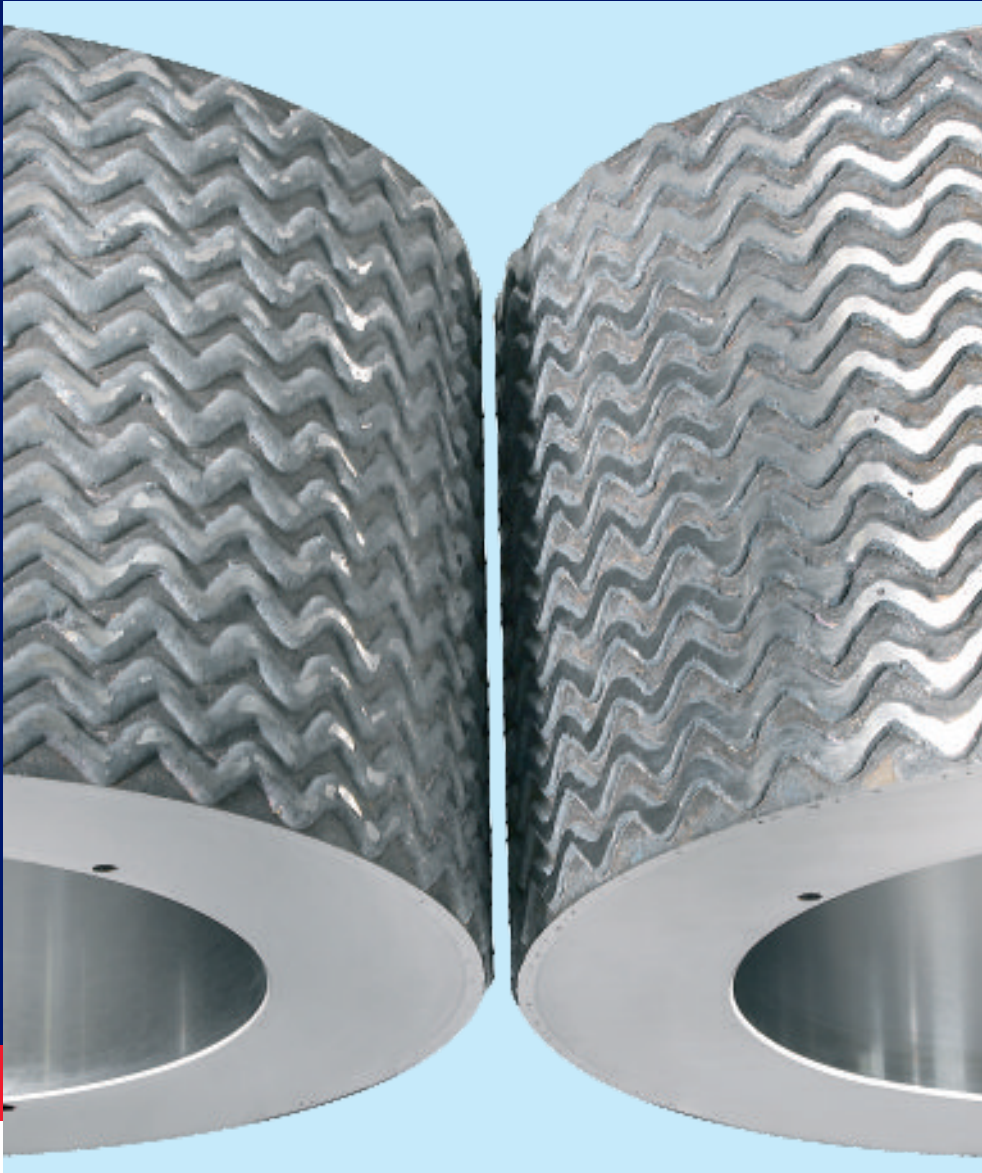

HOSOKAWA ALPINE Compaction

A Division of HOSOKAWA ALPINE Aktiengesellschaft

HIGH PRESSURE ROLLER GRINDING

Pressure on Particles

Principle of grinding

The working principle of the High Pressure Roller Mill is two rolls, which are counter rotating at the same circumferential speed. One roll is connected to a hydraulic system which creates a radial force.

The feed to the rolls creates a so called "bed" of material in the roll gap. Within this material bed, the product is intensely compacted and the strain that the single particles have on each other effects them being ground.

Materials with good flowing properties and high bulk densities need just the gravity flow to feed the machine.

Materials which are light and have poor flowing properties are fed into the roll gap by a pre-densifying screw which moreover increases the mill's efficiency in a significant way.

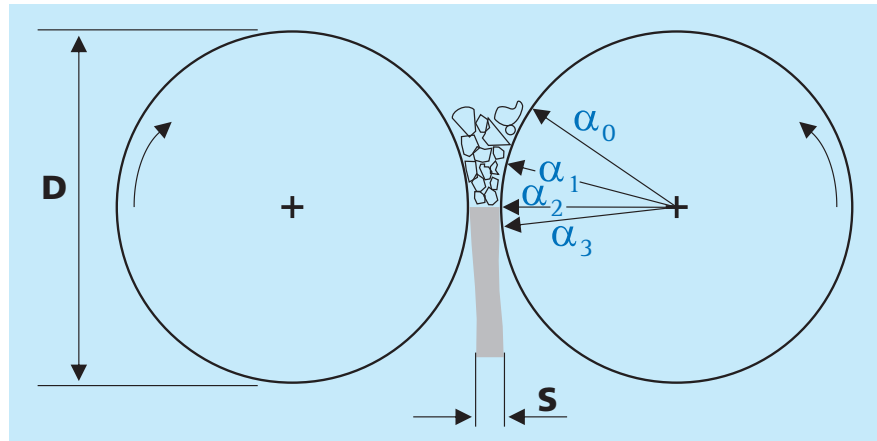

The grinding process

a₀: The product enters the roll gap.
 a₁: Press force builds up and the grinding starts.

a₂: The density is now 85 – 90% - a flake with the thickness "s" is formed.
 a₃: A small expansion occurs when the product leaves the high pressure zone.

Typical applications

Samples:

- Alumina
- Blast-furnace slag
- Clinker
- Coke (wet)
- Corundum
- Dolomite
- Feldspar
- Fireclay
- Fused magnesite
- Limestone
- Magnesite ore
- Metal oxides
- Ores
- Pegmatite
- Quartz, silica
- Silicon
- Silicon carbide
- Technical ceramics
- Titanium dioxide
- Wollastonite

It's the right process

High Pressure Roller Grinding is suitable for brittle materials which are in the higher end of the Mohs hardness.

Crushing in one simple pass is already resulting in particle sizes of 80 – 90 µm.

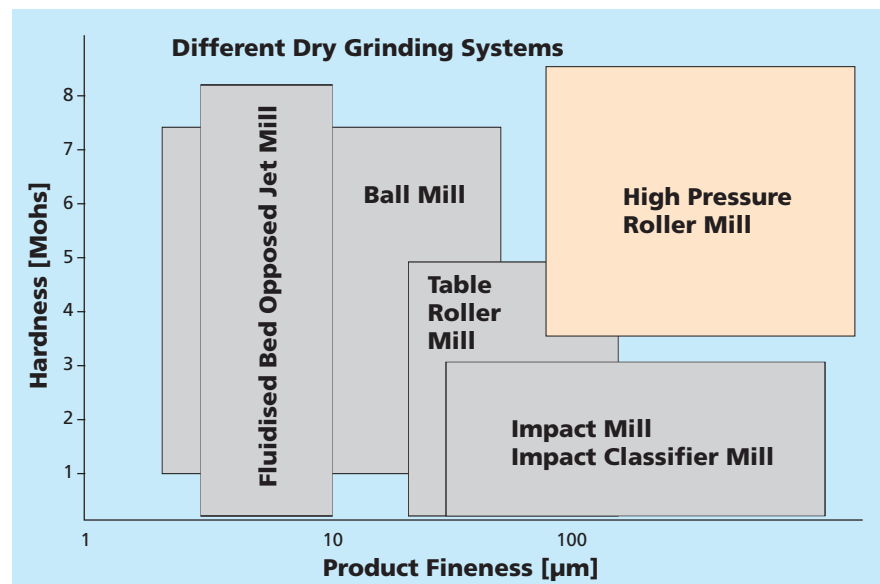

Grinding processes offered by the Hosokawa Group

MACHINES AND SYSTEMS

... one spot shopping

In most cases, just one operation cycle of High Pressure Roller Grinding is required in order to receive the desired grinding result.

Medium-hard products often turn to flakes when being grinded. Those flakes are afterwards desagglomerated with a Disintegrator. Desagglomeration additionally opens the secondary cracks in the particles and thus even further increases the yield of fines.

If the final product is required to be extremely fine or if the maximum particle size is precisely given, a screener or an air classifier is used after grinding.

The coarse particles are returned the High Pressure Roller Mill where they are once more grinded. The loop is completely closed.

The Alpine pilot plant

Six decades of know how in compacting technology make testing in the Alpine pilot plant an expertise experience. Visit us in our test centre for carrying out tests with your product that meet your requirements. The detailed test report, the samples and the design data of the production plant that you receive after the tests will serve as a solid basis for your project's progress.

For us at Hosokawa Alpine Compaction, the tests provide valuable information on how the machine or plant has to be designed in order to meet the product properties and the customer's specifications.

Share with us our experiences to ensure a smooth start into your production.

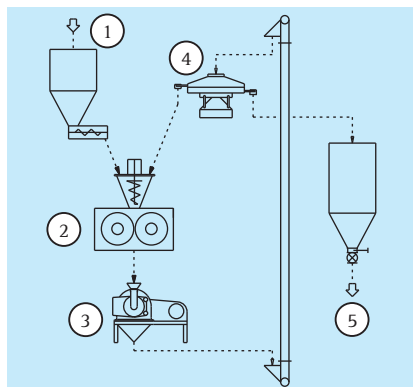

Grinding System for an end product of $d_{90} < 80 \mu\text{m}$

- ① Raw material
- ② Kompakor - High Pressure Roller Mill
- ③ Desintegrator
- ④ Screening machine or air classifier
- ⑤ Final product

Energy consumption

The press force of the mill acts directly on the particle bed in the roll gap. Consequently, the total energy is used for the size reduction process. Crushing in one single passage needs a specific energy of 3 – 6 kWh/to. Running in a closed loop with a screener or an air classifier is somewhat increasing the energy consumption.

Advantages of the High Pressure Roller Mill

- low energy consumption
- low percentage of objectionable fines
- no considerable wear
- low-noise operation
- required space is small
- high availability
- sharp-edged particles

More . . .

than just high pressure roller grinding is available. We have also mixers, screening machines and mills for desagglomeration available and can simulate a closed loop process.



Laboratory for particle size analysis, moisture control and density.

System engineering

Besides single machines, we moreover supply complete plants with any accessories including control and automation.



High Pressure Roller Mill in pilot plant

ECONOMIC AND RELIABLE Solutions against wear and contamination

Hosokawa Alpine has six decades of experience in manufacturing compacting and briquetting machines which, by the way, work with much higher press forces and drive power than required for High Pressure Roller Grinding. Our customers benefit from our experience being supplied with a technology that stands out for its economic efficiency and for its high reliability.

The optimum material of construction is selected and processed in accordance with highest quality standards in our production site in Germany.

We provide the know-how for regeneration and repair to our customers.

Most products that are processed with the High Pressure Roller Mill are strongly abrasive. Therefore, the costs for wear are a substantial part of the operating costs. The High Pressure Roller Mills are equipped with rolls that have a very long and therefore economic service life. Contamination of the product from roll abrasion is very low.

Roll surfaces

The size and shape as well as the build-up welding are customized to every application case.

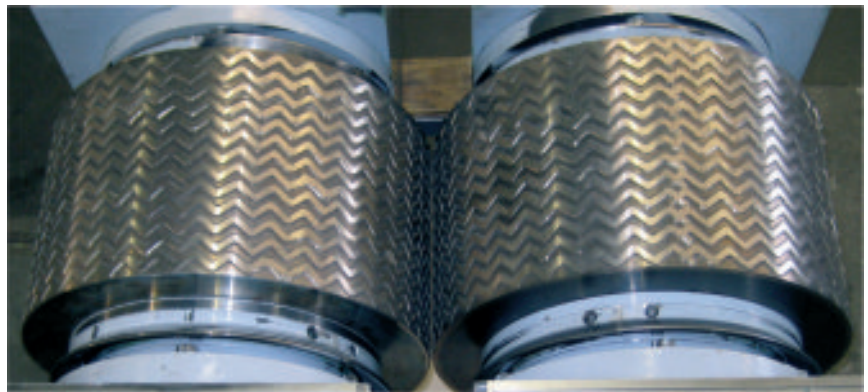

Segments

for hot and abrasive materials. Segments can be exchanged without dismantling the bearings and the roll shaft.

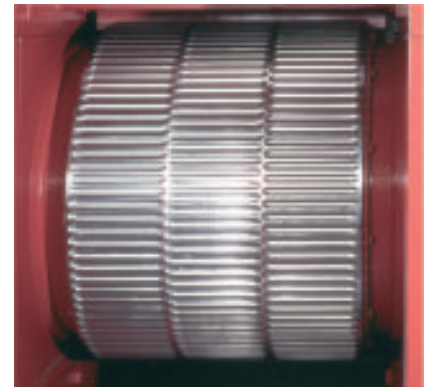

Roll tires

with surface hardening made of stainless steel.



Pre-densifying screw
with hard overlay weld.



TECHNOLOGY AT ITS BEST

Details that make the difference

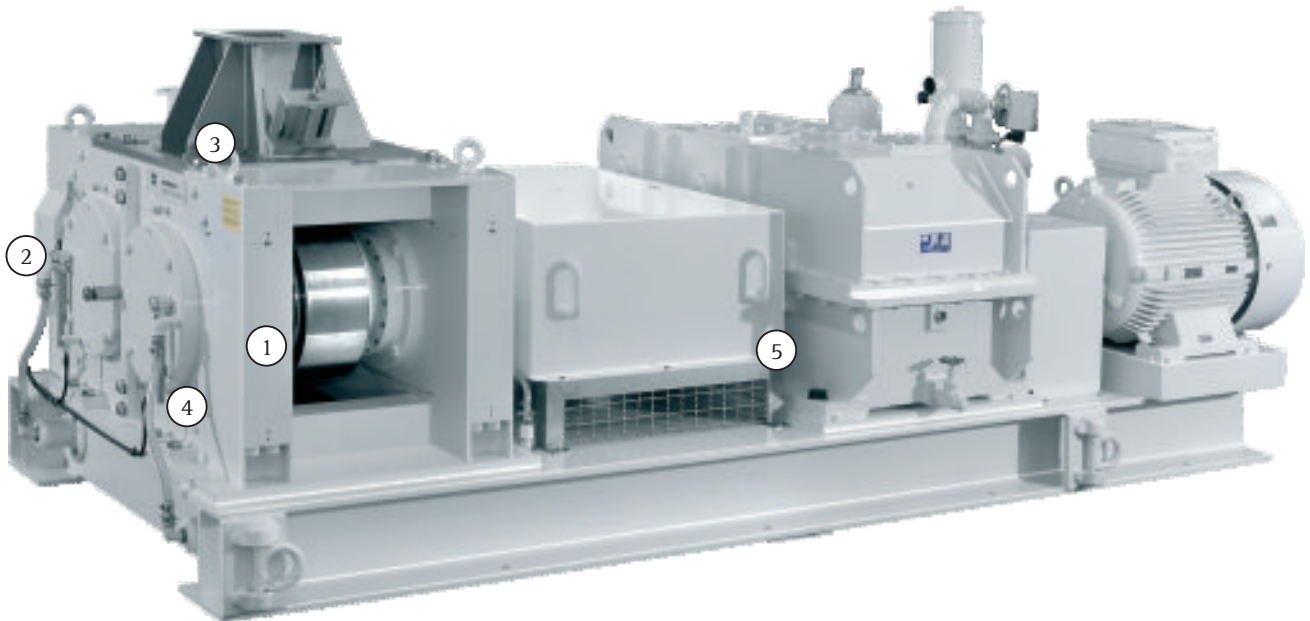

Front side

- ① Press frame with rollers
- ② Electronic strain gauge to measure the press force
- ③ Material feeding and dosing
- ④ Air purged seals of bearings
- ⑤ Dual shaft gear reducer with gear couplings

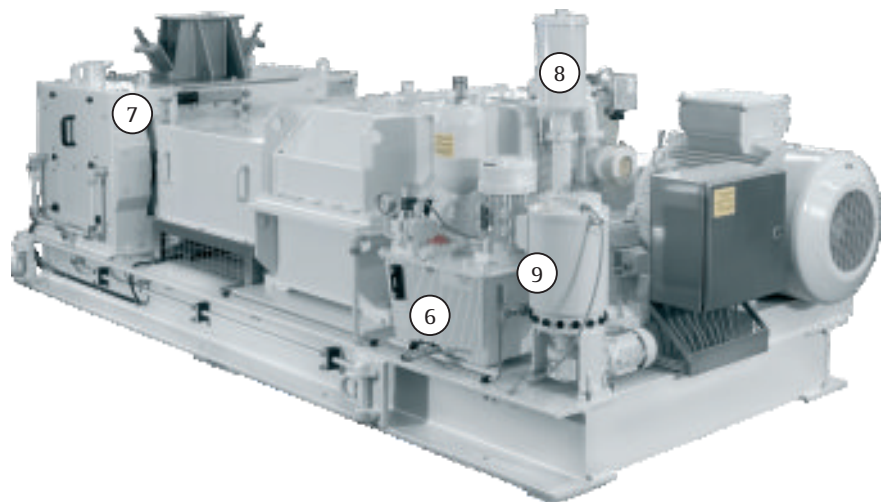

Drive side

- ⑥ Hydraulic unit
- ⑦ Sensor for the roll gap
- ⑧ Blower for the air purging system
- ⑨ Automatic lubrication system

The machine range meets any requirements concerning grinding force and throughput capacity.

Roll diameter:	300 - 1.100 mm
Roll width:	100 - 800 mm
Grinding force:	2 - 10 N/mm ²

Grinding without contamination

Whether silicon for semiconductor purposes or titanium dioxide for paints, food and pharma, the High Pressure Roller Mills of Hosokawa Alpine ensure a grinding process free from any contamination. The well-proven roller bearing with purged air seal guarantees that the product does not get into contact with grease.

Automation

High degree of automation and quality assurance are guaranteed by the reliable signals from measuring the gap between the rolls and electronically measuring the actual press force. You know at any time how your product is ground in full automatic mode even without operating personnel.

Heavy duty layout

Tapered roller bearings installed on a heavy press frame assure a long service life and high availability of the High Pressure Roller Grinder.

The drive package is designed for high and alternating shock loads during grinding.

HOSOKAWA ALPINE

Agglomeration Technology

We bring your powder into shape



HOSOKAWA ALPINE Compaction

P.O. Box 1152
D-74207 Leingarten / Germany
Tel.: ++49 (0)7131 / 898669-0
Fax: ++49 (0)7131 / 898669-309

E-Mail:
compaction@alpine.hosokawa.com

Delivery address:
Daimlerstr. 8
D-74211 Leingarten / Germany

The ALPINE Technologies

Machines and complete plants for

- Compaction
- Briquetting
- Granulation
- Size reduction
- Pelletizing
- Extrusion
- Spheronization

Registered Trademarks:

Kompaktor®
Pharmapaktor®



HOSOKAWA ALPINE Compaction

A Division of HOSOKAWA ALPINE Aktiengesellschaft

Hosokawa Alpine Compaction is a member of the Hosokawa Micron Group, responding to global needs through emphasis on materials science and engineering. The Group is an international provider of equipment and technology for powder and particle processing, plastics processing and confectionery products. The Group maintains facilities for research, engineering, manufacturing and service in each of the world's major industrial markets.