

**HOSOKAWA MICRON**

**Process Technologies For Tomorrow**

**ALPINE**



**HOSOKAWA ALPINE**

# **Agitated Wet Mill Rührwerkskugelmühle**

## **Alpine Hydromill AHM**

# Agenda



**HOSOKAWA ALPINE**

- 1. Design  
Aufbau**
- 2. Advantages  
Vorteile**
- 3. Particle size distributions  
Kornverteilungen**
- 4. Different operation  
Verschiedene Betriebsweisen**
- 5. Flowsheets**
- 6. References/Referenzen**

# 1. Alpine Hydromill AHM

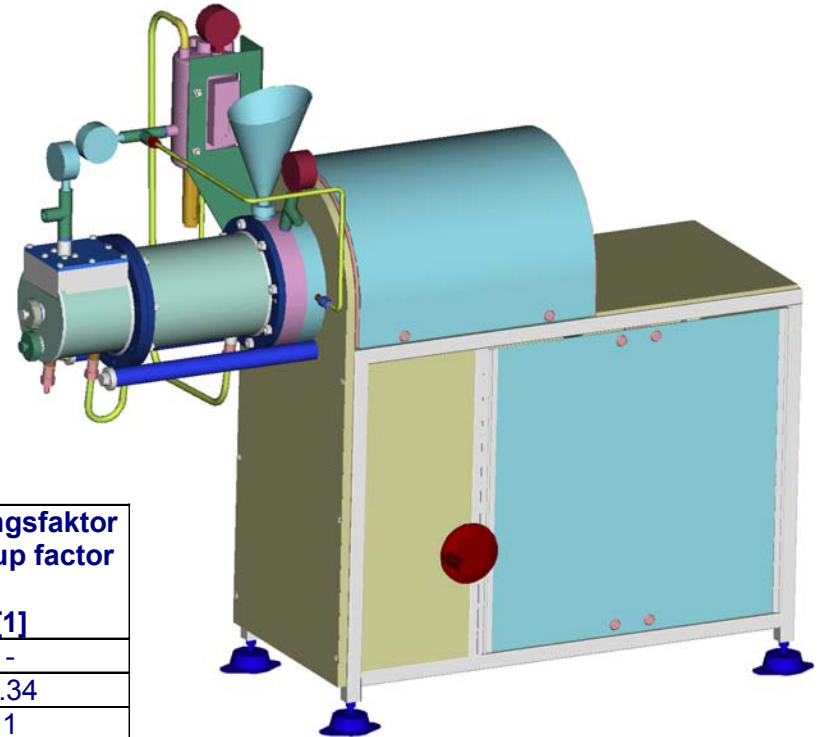

	Mahlraum- volumen mill volume [Liter]	Motorleistung motor power [kW]	Leistungsfaktor Scale-up factor [1]
<b>90 AHM</b>	0.25-1.1	2.2	-
<b>132 AHM</b>	5	7.5	0.34
<b>200 AHM</b>	17	22	1
<b>315 AHM</b>	65	45	2.05
<b>400 AHM</b>	132	75	3.4
<b>475 AHM</b>	221	110	5
<b>630 AHM</b>	516	200	9.1
<b>800 AHM</b>	1056	315	14.3



# Design / Aufbau

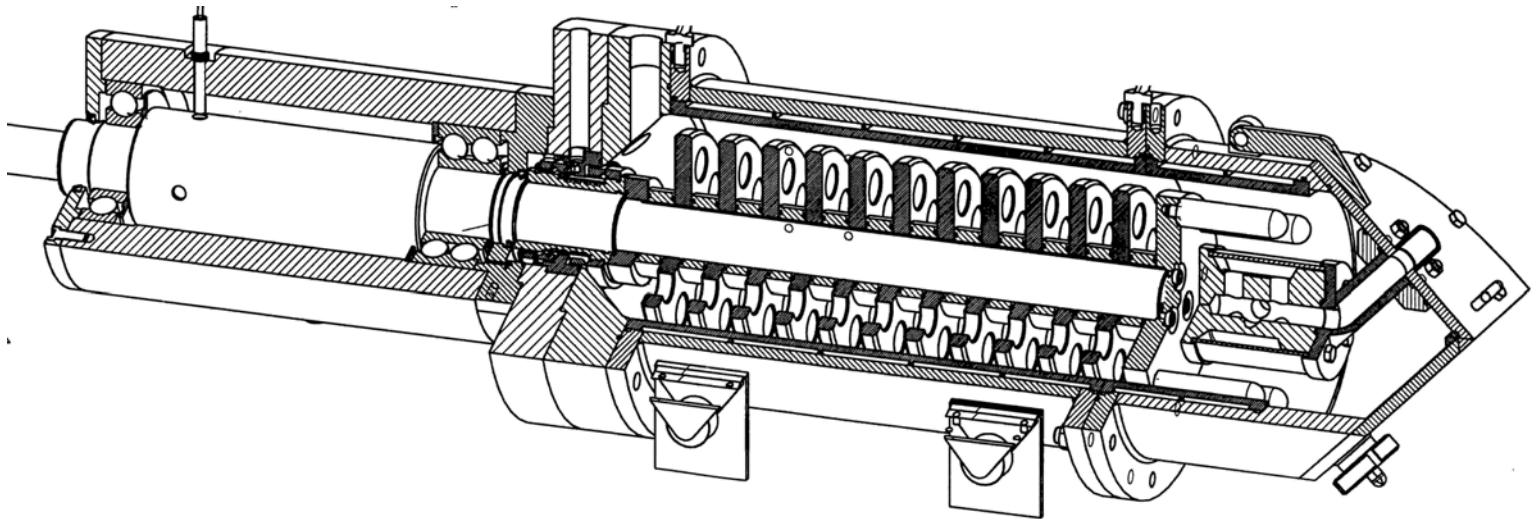



**HOSOKAWA ALPINE**

## Agitator Discs

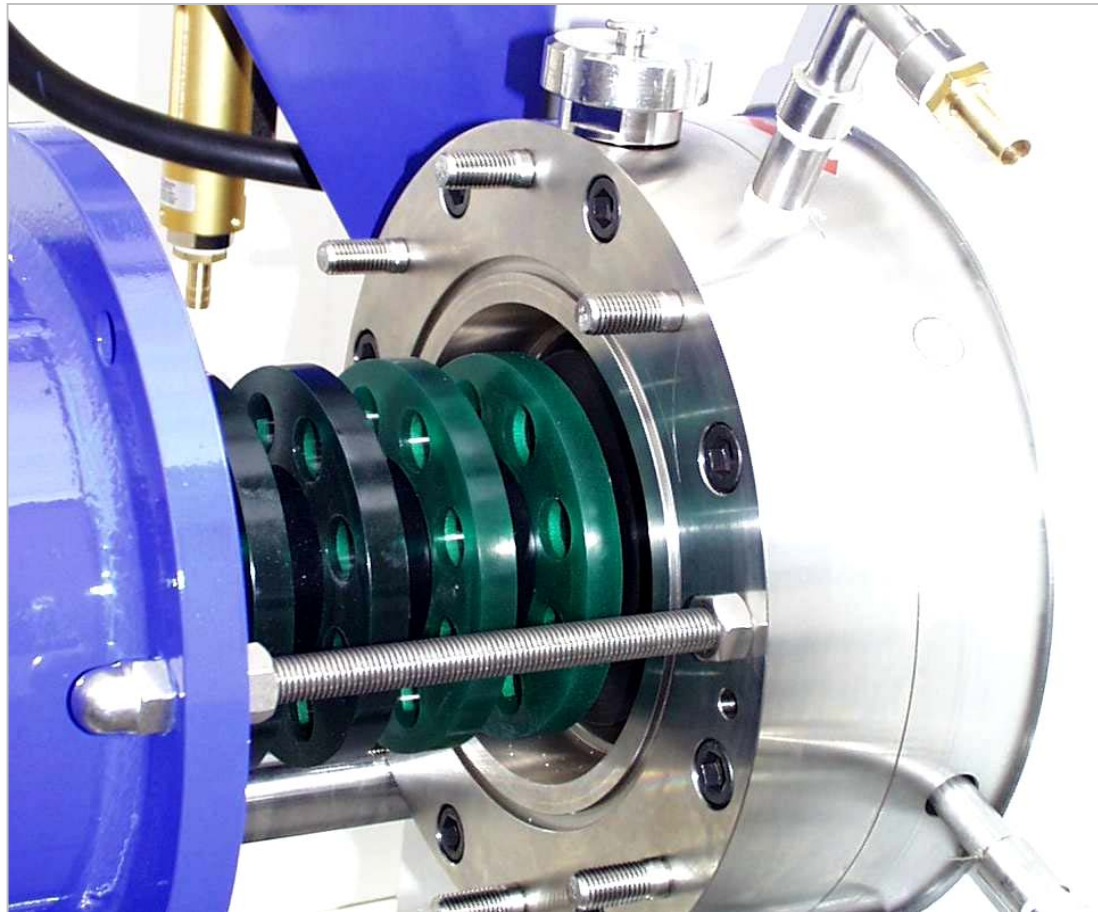



## Screen Section





**HOSOKAWA ALPINE**

# 200 AHM







**HOSOKAWA ALPINE**

# 315 AHM





**HOSOKAWA ALPINE**

**400 AHM**

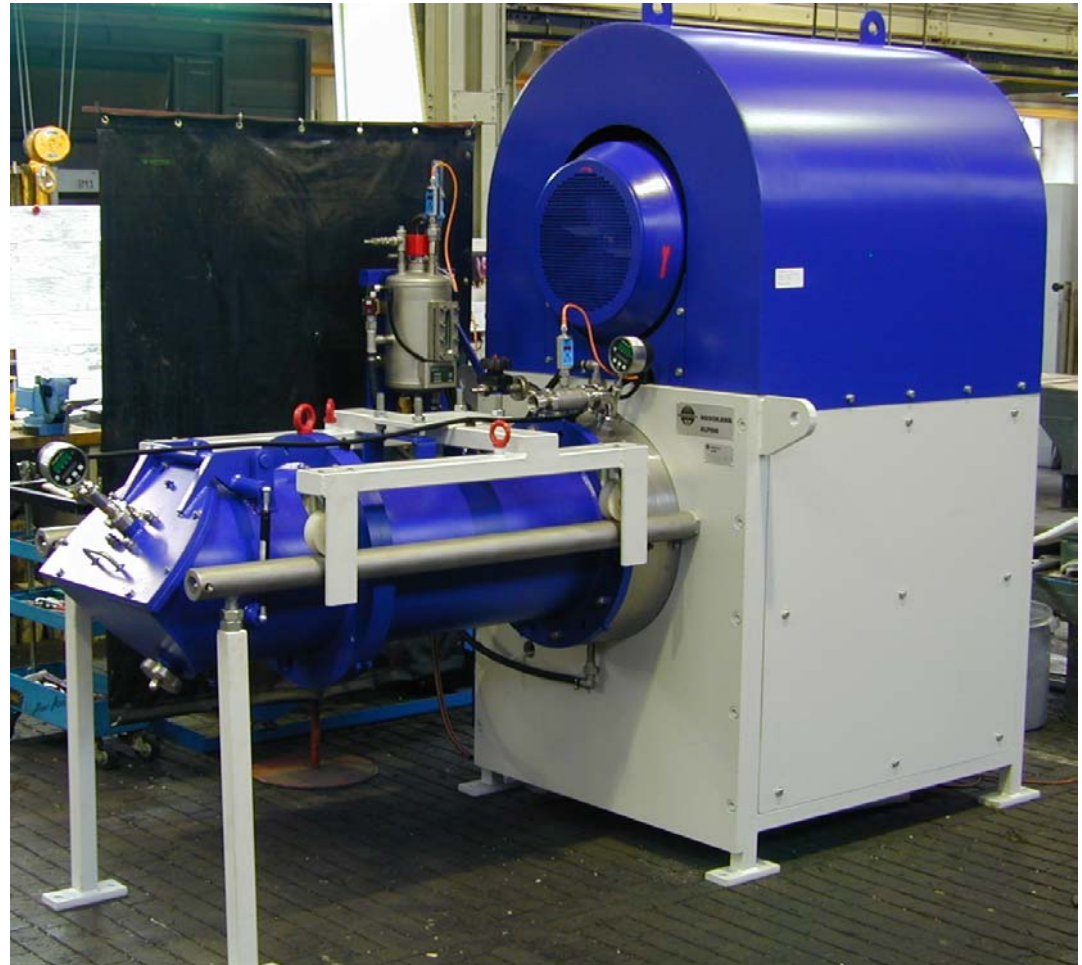



**AHM wear parts  
in various  
materials**

**AHM  
Verschleißteile  
in verschiedenen  
Werkstoffen**





**AHM casing  
with various  
insertion pipes**

**AHM Gehäuse  
mit verschiedenen  
Einschubrohren**





## **2. Advantages of Alpine Hydromill**

- Flexible wear protection system**
- Screen exchangeable without emptying**
- Mill easy accessible from all sides**
- steep particle size distributions**
- Sturdy, double acting mechanical seal**



## **2. Vorteile der Alpine Hydromill**

- Flexibles Verschleißschutzsystem**
- Sieb austauschbar bei gefüllter Mühle**
- von allen Seiten gut zugänglich**
- Steile Kornverteilungen**
- Solide, doppelwirkende Gleitringdichtung**



### **3. Particle size distributions Kornverteilungen**

- Magnesiumhydroxide**
- Yttria stab. Zircon Oxide**
- Silicon Nitride**
- Pegmatite**
- Quartz**



# Magnesiumhydroxide

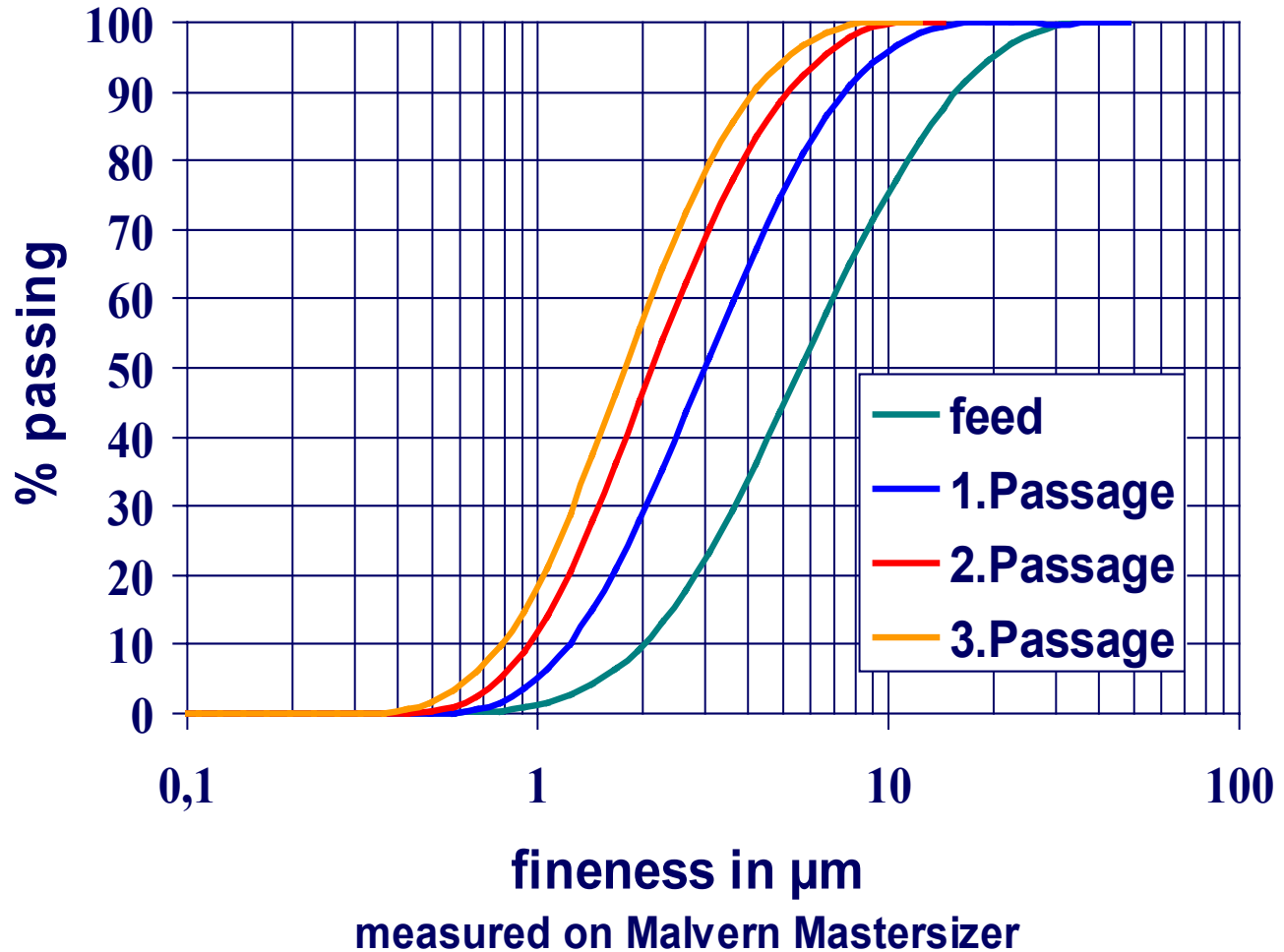





# Yttria stab. Zirconoxide ZrO<sub>2</sub>

spec. energy input: 660 kWh/t

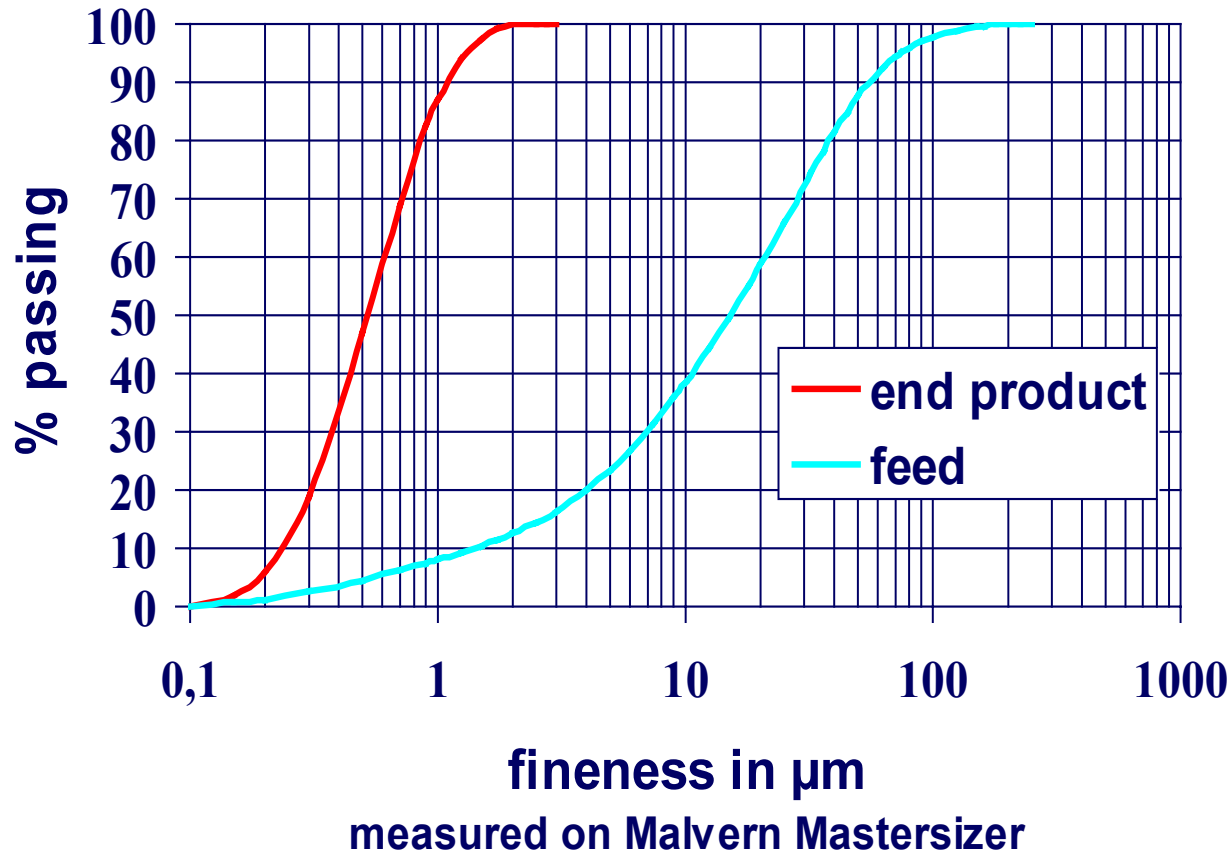



# Silicon Nitride Si<sub>3</sub>N<sub>4</sub>

spec. energy input: 490 kWh/t

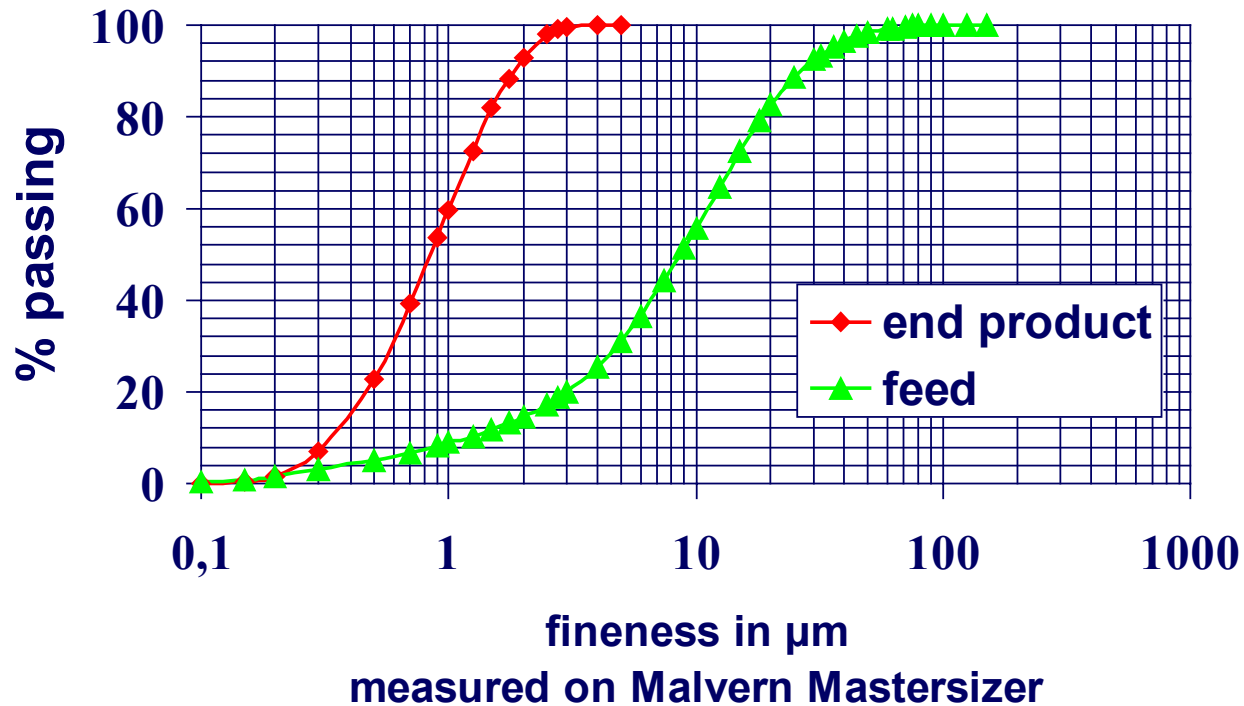



# Pegmatite

spec. energy input: 220 kWh/t

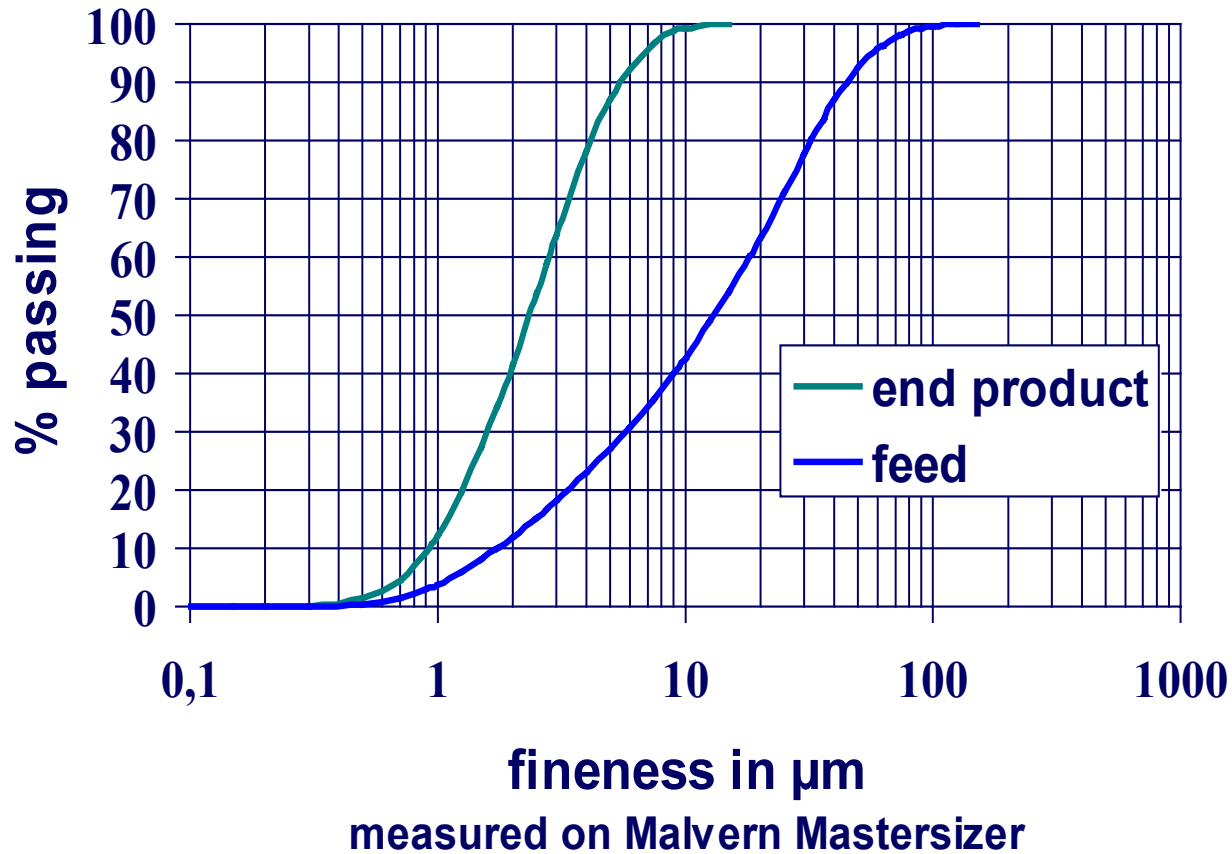



# Quartz

spec. energy input: about 750 kWh/t

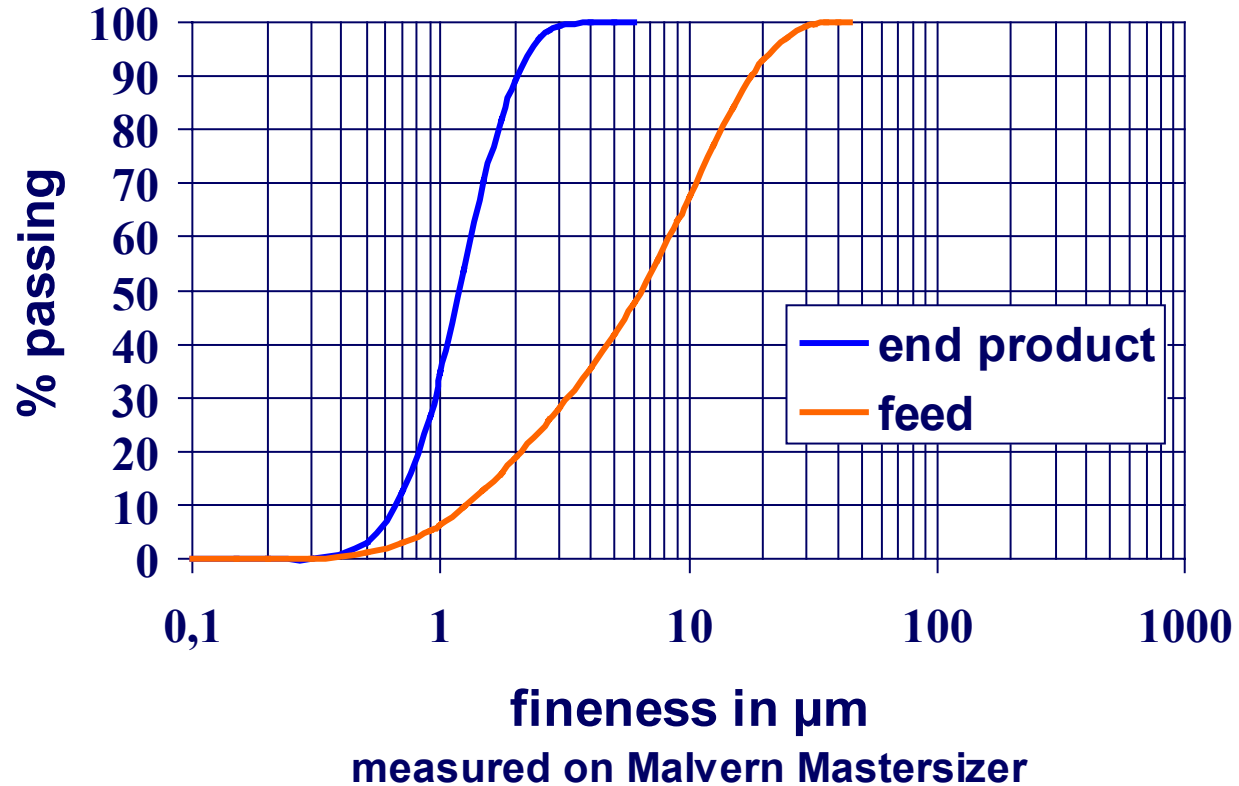

# 4. Different Operation / Betriebsweisen

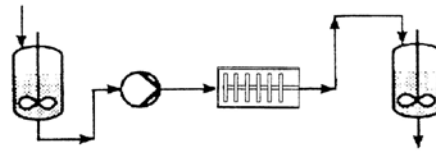

Chargenfahrweise mit 1 Passage

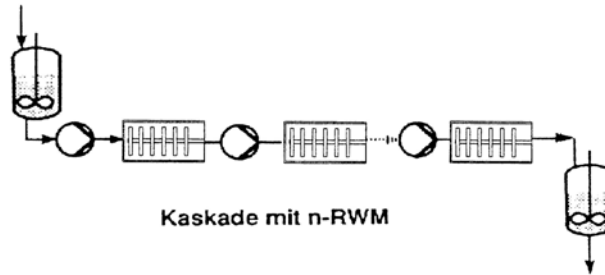
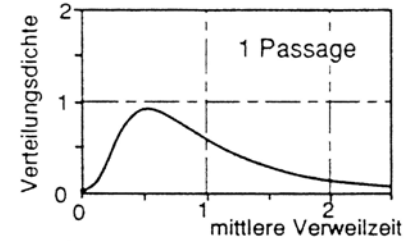

Kaskade mit n-RWM

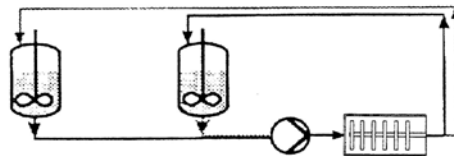
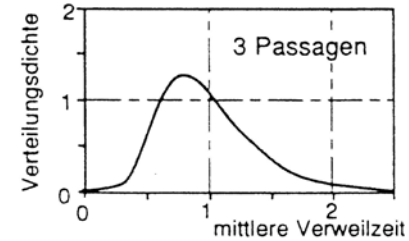

Pendelfahrweise

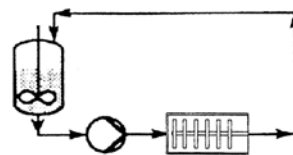
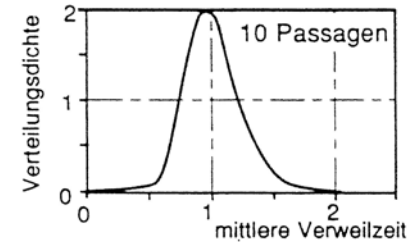

Kreisfahrweise mit Rückführung in Rührbehälter

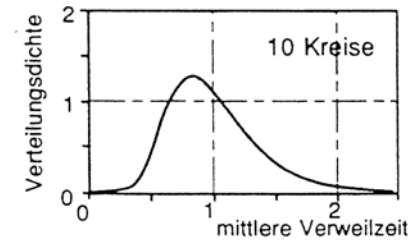



# 5. Flowsheets: Continuous Operation Kontinuierliche Fahrweise

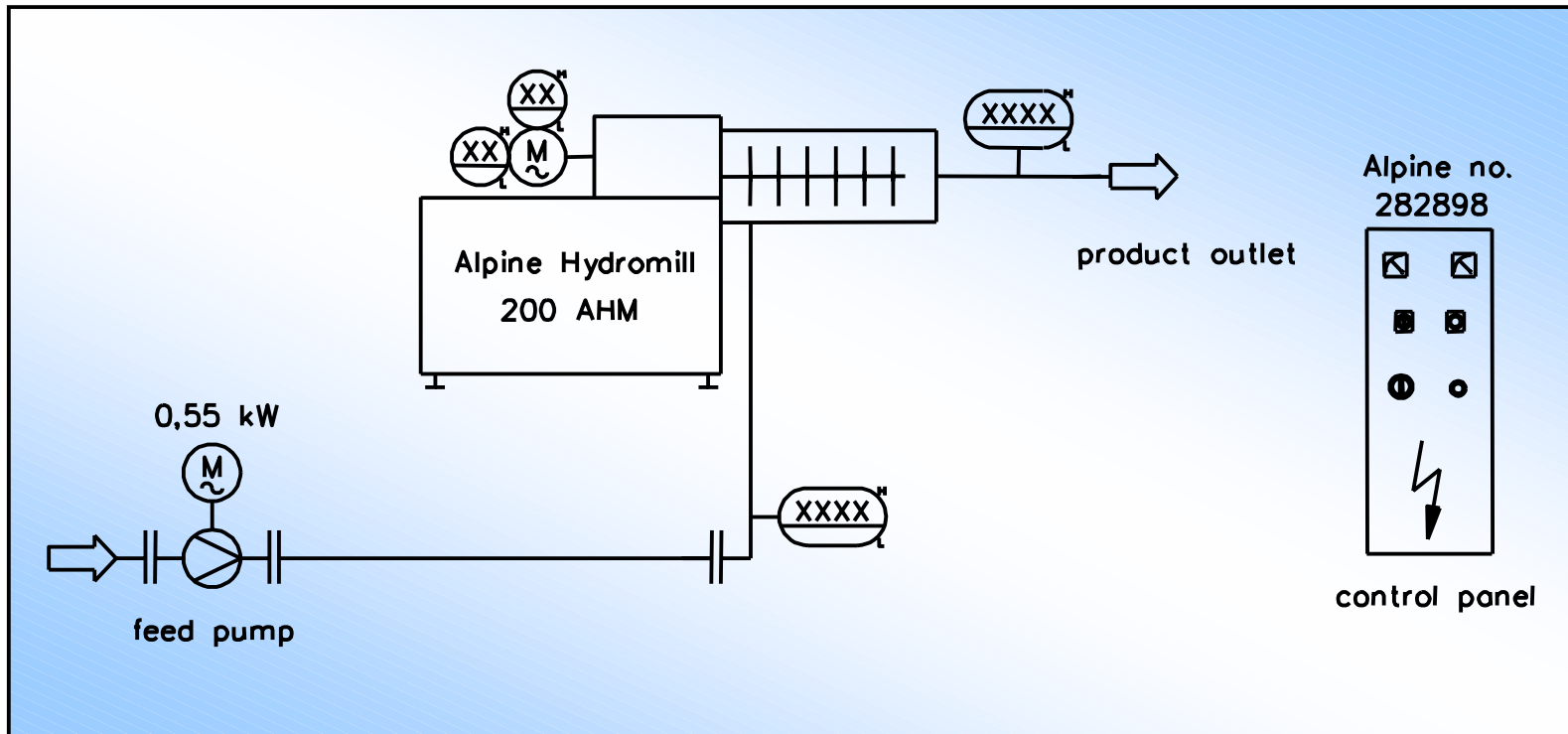

# Circuit process / Kreislauffahrweise

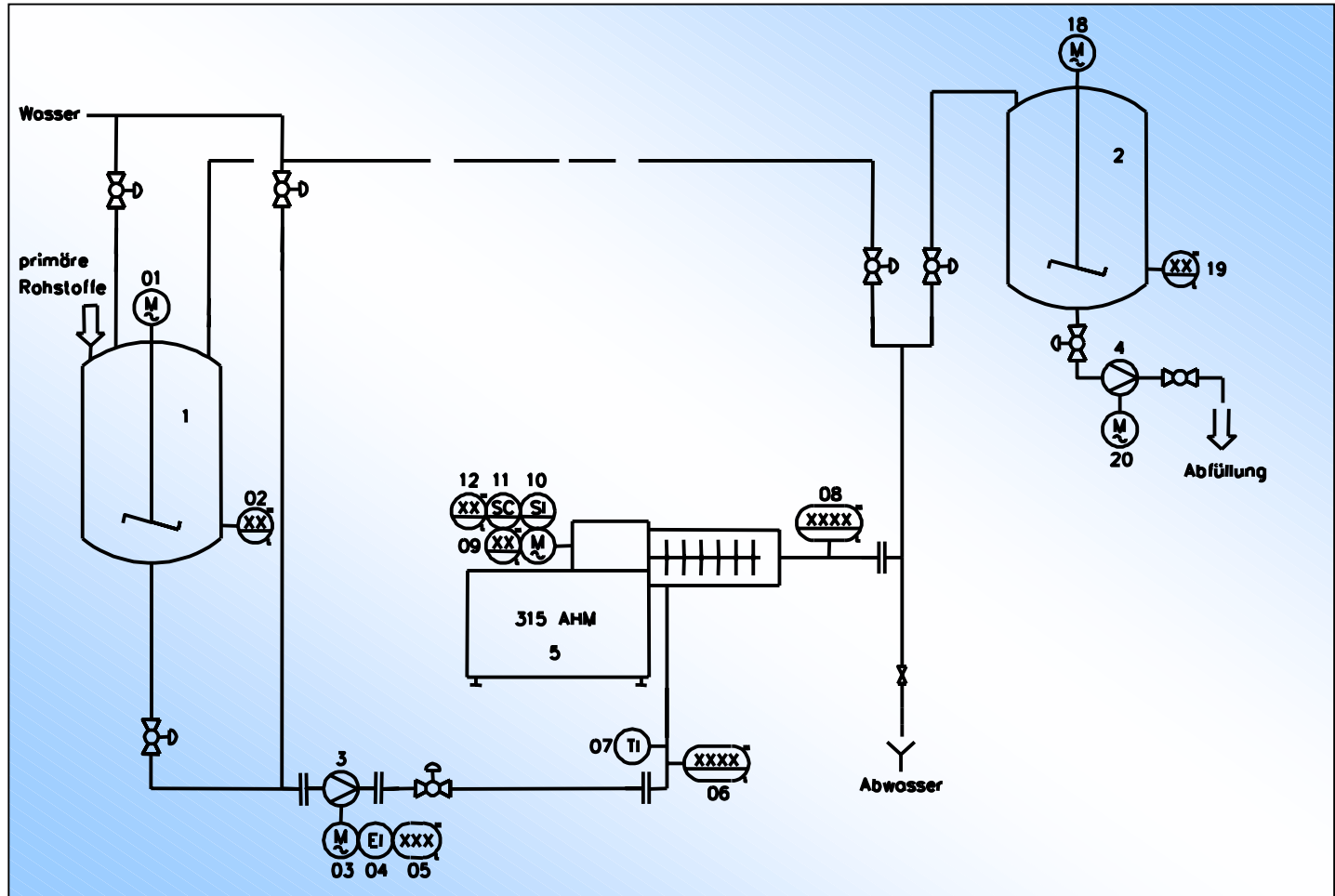

# Wet Grinding Plant with Slurry Preparation Naßmahlanlage mit Suspensionsvorbereitung

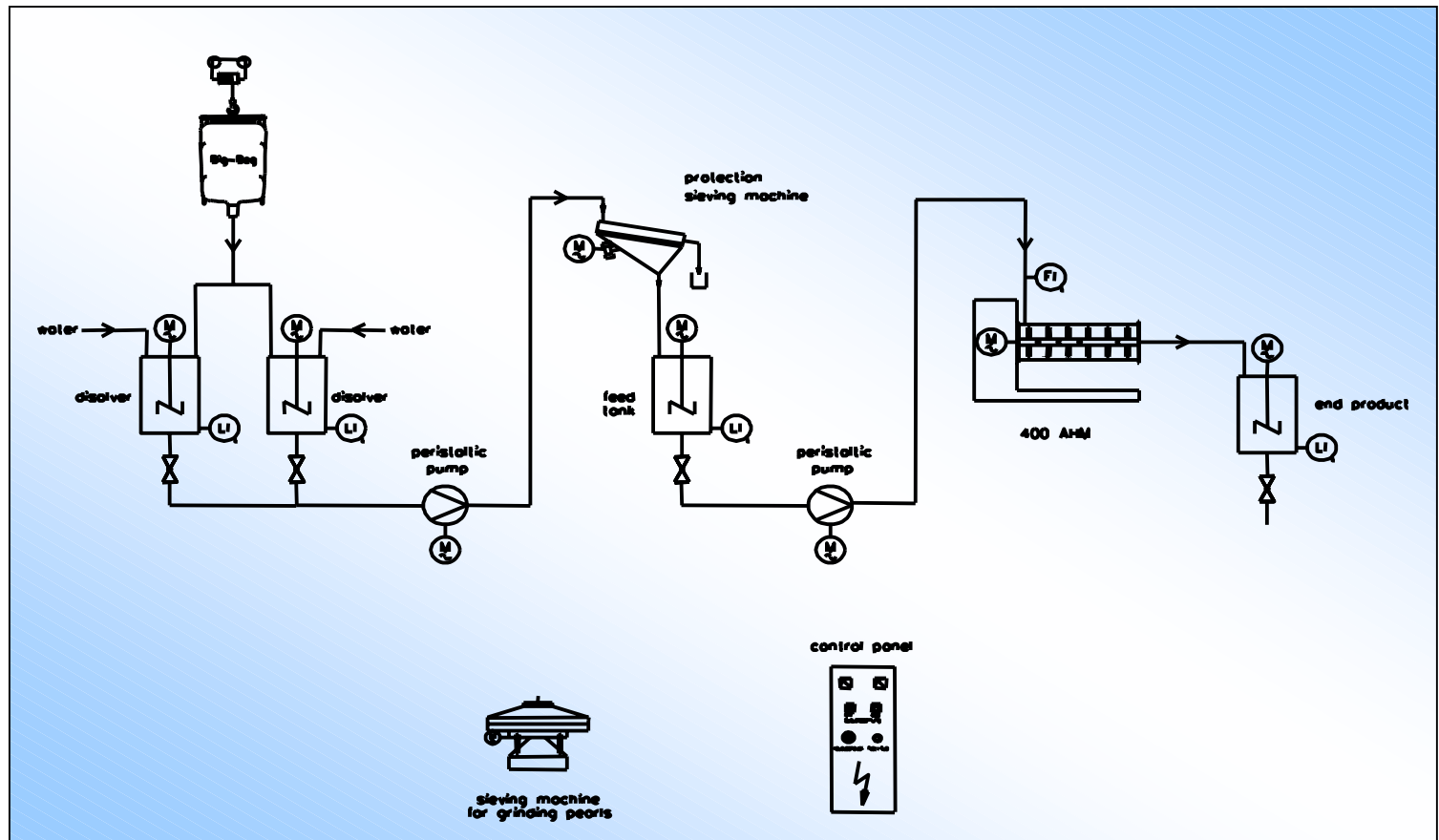





## **6. Extract of “References AHM”**

- 😊 **200 AHM for MgO in Germany**
- 😊 **200 AHM for ZrO<sub>2</sub> in Germany**
- 😊 **200 AHM for food additives in Germany**
- 😊 **2x200 AHM for ZrO<sub>2</sub> in China**
- 😊 **200 AHM for plant protective agents in Iran**
  
- 😊 **315 AHM for Si<sub>3</sub>N<sub>4</sub> in Spain**
- 😊 **315 AHM for fungicides in Germany**
  
- 😊 **400 AHM for NiCO<sub>3</sub> in Finland**
- 😊 **2x400 AHM for Antrachinone in Sweden**



**HOSOKAWA ALPINE**

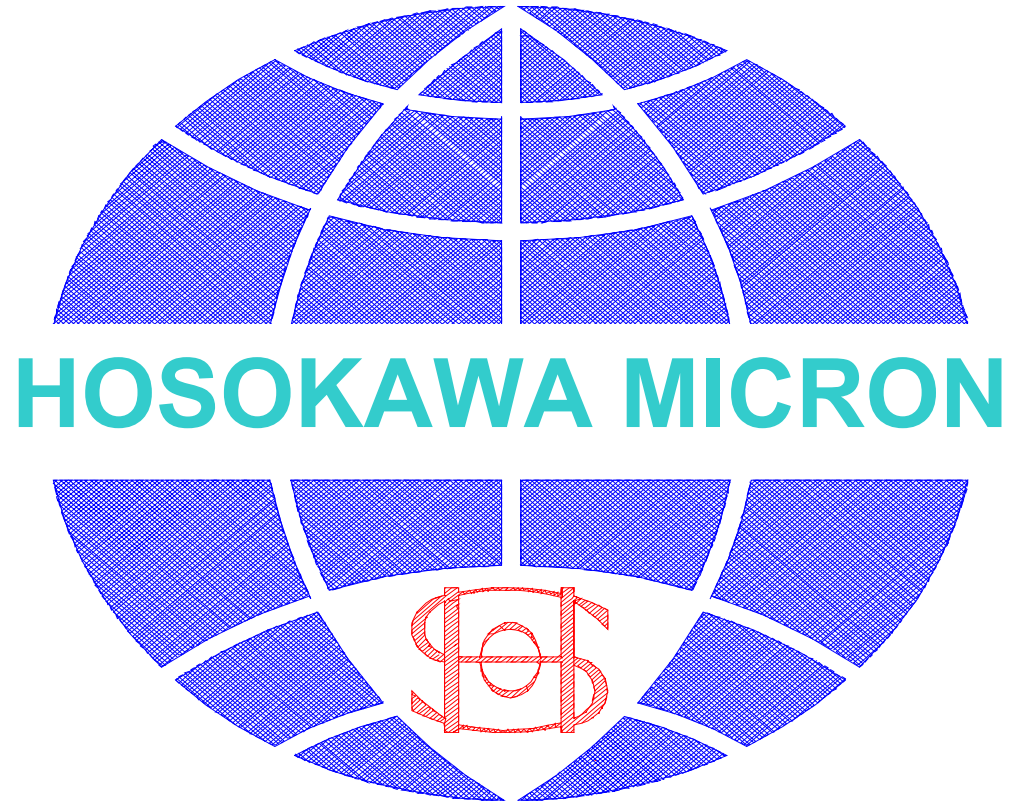

**Process Technologies For Tomorrow**